



High Power LED

Edixeon®

1W Edixeon®

Emitter

Approved By Customer	Designer	Checker	Approval

Date : 2006/11/13

Version : 3.3

Device No. : 3-RD-01-E0001
EDISON OPTO CORPORATION
4F, No. 800, Chung-Cheng Rd,
Chung-Ho, Taipei 235, Taiwan
Tel: 886-2-8227-6996
Fax: 886-2-8227-6997
<http://www.edison-opto.com.tw>



1W Edixeon®



Edixeon® emitters are one of the highest flux LEDs in the world by Edison Opto. Edixeon® emitters are designed to satisfy more and more Solid-State lighting High Power LED applications for brilliant world such as flash light, indoor and outdoor decoration light. Edixeon® emitters are designed by particular package for High Power LED. 1W Edixeon® white has typical 55 lumens @350mA. Unlike most fluorescent sources, Edixeon contains no mercury and has more energy efficient than other incandescent light source.

Features

- Various colors
- More energy efficient than incandescent and most halogen lamps
- Low voltage operated
- Instant light
- Long operating life

Typical Applications

- Reading lights
- Portable flashlight
- Up-lighters and Down-lighters
- LCD Backlights
- General lighting
- Contour lights
- Ceiling lights
- Garden lighting
- Decoration lights
- Architectural lighting
- Beacon lights

Edixeon Technology

- $T_{jmax} = 125^{\circ}\text{C}$
- High Lumen performance
- Low thermal resistance $15\text{-}18^{\circ}\text{C/W}$
- RoHS compliant
- Industrial best lumen maintenance — 50,000hrs life at I_{Fmax} with 70% lumen if T_j is lower than 70°C



Package Outlines

Lambertian

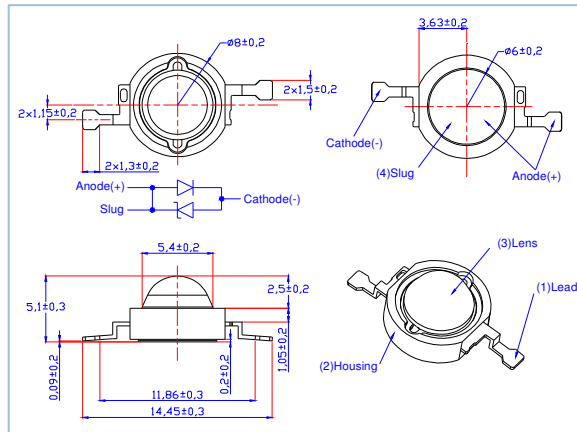

Side Emitting

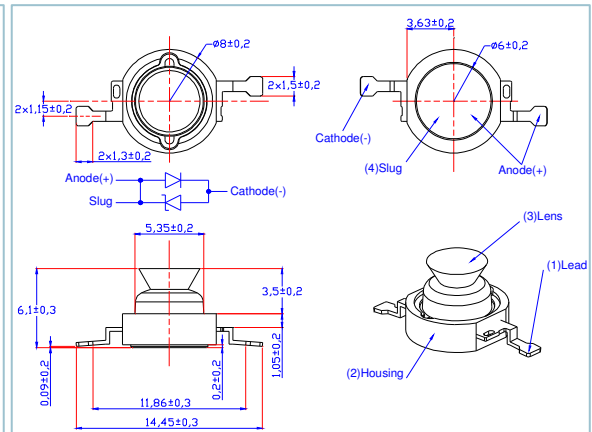

Batwing

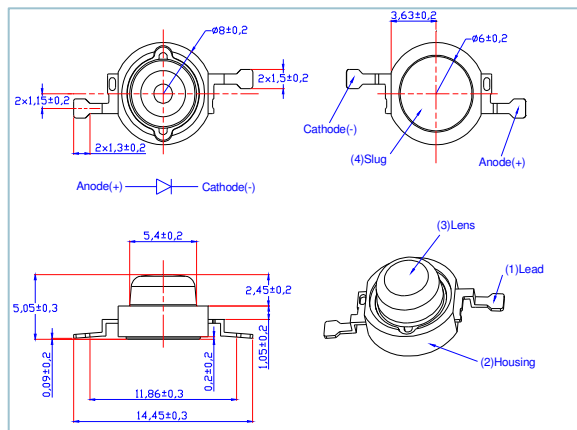

Focusing

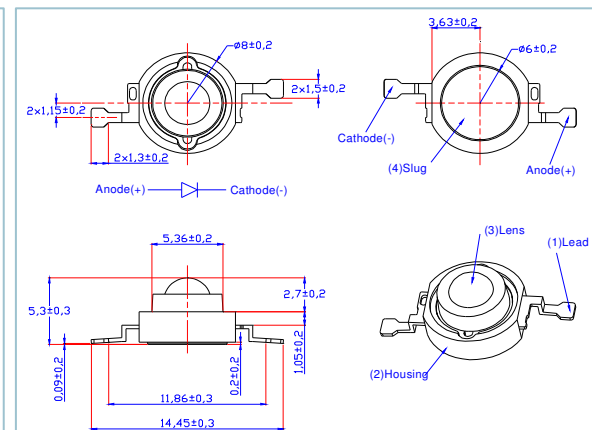

Notes:

1. All dimensions are in mm.
2. Drawings are not to scale.
3. It is strongly recommended that the temperature of lead be not higher than 55°C .
4. Lambertian and side emitting series slug has polarity as anode.
5. It is important that the slug can't contact aluminum surface, It is strongly recommended that there should coat a uniform electrically isolated heat dissipation film on the aluminum surface.

Absolute Maximum Ratings

Parameter	Symbol	Rating	Units
DC Forward Current	I_F	350	mA
Peak pulse current;(tp ≤ 100μs, Duty cycle=0.25)	I_{pulse}	500	mA
Reverse Voltage	V_R	5	V
Forward Contact Voltage	V_{FC}	16	V
LED junction Temperature	T_j	125	°C
Operating Temperature	T_{opr}	-30 ~ +110	°C
Storage Temperature	T_{stg}	-40 ~ +120	°C
ESD Sensitivity (Lambertian and Side emitting)	V_B	4,000	V
ESD Sensitivity (Batwing and Focusing)	V_B	500	V
Manual Soldering Time at 260°C (Max.)	T_{sol}	5	seconds

Notes:

1. Proper current derating must be observed to maintain junction temperature below the maximum.
2. LEDs are not designed to be driven in reserve bias.

Luminous Flux & Radiometric Power^[1] Characteristics at I_F=350mA(T_J=25°C):

Lens Item	Part Name	Color	Flux			Units
			Min.	Typ.	Max.	
Lambertian Side Emitting	EDEW-1xA1	White	30.3	55.0	--	lm
	EDEW-1xA6	White	30.3	45.0	--	lm
	EDEW-1xA7	White	30.3	60.0	--	lm
	EDEX-1xAx	Warm White	17.9	40.0	--	lm
	EDER-1xAx	Red	23.3	45.0	--	lm
	EDEO-1xAx	Red Orange	23.3	45.0	--	lm
	EDEA-1xAx	Amber	23.3	40.0	--	lm
	EDET-1xAx	True Green	30.3	60.0	--	lm
	EDEB-1xAx	Blue	8.2	15.0	--	lm
	EDEC-1xAx	Royal Blue ^[1]	113.9	220	--	mW

Lens Item	Part Name	Color	Flux			Units
			Min.	Typ.	Max.	
Batwing Focusing	EDEW-1xAx	White	30.3	45.0	--	lm
	EDEX-1xAx	Warm White	17.9	40.0	--	lm
	EDER-1xAx	Red	23.3	40.0	--	lm
	EDEO-1xAx	Red Orange	23.3	40.0	--	lm
	EDEA-1xAx	Amber	23.3	38.0	--	lm
	EDET-1xAx	True Green	30.3	50.0	--	lm
	EDEB-1xAx	Blue	8.2	13.0	--	lm
	EDEC-1xAx	Royal Blue ^[1]	113.9	200	--	mW

Forward Voltage Characteristics at I_F=350mA(T_J=25°C):

Lens Item	Part Name	Color	V _F			Units
			Min.	Typ.	Max.	
Lambertian Side Emitting Batwing Focusing	EDEW-1xAx	White	3.1	--	4.0	V
	EDEW-1xA6	White	3.1	--	4.3	V
	EDEW-1xA7	White	2.8	--	3.7	V
	EDEX-1xAx	Warm White	2.8	--	4.3	V
	EDER-1xAx	Red	2.0	--	3.0	V
	EDEO-1xAx	Red Orange	2.0	--	3.0	V
	EDEA-1xAx	Amber	2.0	--	3.0	V
	EDET-1xAx	True Green	2.8	--	4.0	V
	EDEB-1xAx	Blue	3.1	--	4.3	V
	EDEC-1xAx	Royal Blue	3.1	--	4.3	V

**Dominant Wavelength or Peak wavelength^[1] or Color Temperature
Characteristics at I_F=350mA(T_j=25°C):**

Lens Item	Part Name	Color	$\lambda_d/\lambda_p^{[1]}/CCT$			Units
			Min.	Typ.	Max.	
Lambertian Side Emitting Batwing Focusing	EDEW-1xAx	White	4500	--	10000	<i>K</i>
	EDEX-1xAx	Warm White	2800	--	3800	<i>K</i>
	EDER-1xAx	Red	620	--	630	<i>nm</i>
	EDEO-1xAx	Red Orange	610	--	620	<i>nm</i>
	EDEA-1xAx	Amber	585	--	595	<i>nm</i>
	EDET-1xAx	True Green	515	--	535	<i>nm</i>
	EDEB-1xAx	Blue	460	--	475	<i>nm</i>
	EDEC-1xAx	Royal Blue ^[1]	440	--	460	<i>nm</i>

**Temperature Coefficient of Forward Voltage & Thermal Resistance Junction to Case
Characteristics at I_F=350mA(T_j=25°C) :**

Lens Item	Part Name	Color	$\Delta V_F/\Delta T$		R _{θJ-B}	
			Typ.	Units	Typ.	Units
Lambertian Side Emitting Batwing Focusing	EDEW-1xAx	White	-2	<i>mV/°C</i>	15	<i>°C/W</i>
	EDEX-1xAx	Warm White	-2	<i>mV/°C</i>	15	<i>°C/W</i>
	EDER-1xAx	Red	-2	<i>mV/°C</i>	18	<i>°C/W</i>
	EDEO-1xAx	Red Orange	-2	<i>mV/°C</i>	18	<i>°C/W</i>
	EDEA-1xAx	Amber	-2	<i>mV/°C</i>	18	<i>°C/W</i>
	EDET-1xAx	True Green	-2	<i>mV/°C</i>	15	<i>°C/W</i>
	EDEB-1xAx	Blue	-2	<i>mV/°C</i>	15	<i>°C/W</i>
	EDEC-1xAx	Royal Blue	-2	<i>mV/°C</i>	15	<i>°C/W</i>

Emission Angle Characteristics at $I_F=350\text{mA}(T_j=25^\circ\text{C})$:

Part Name	Color	$2\Theta_{1/2}(\text{Typ.})$			Units
		Lambertian	Batwing	Focusing	
EDEW-1xAx	White	130	110	80	Degrees
EDEW-1LA6	White	130	--	--	Degrees
EDEW-1LA7	White	120	--	--	Degrees
EDEX-1xAx	Warm White	130	110	80	Degrees
EDER-1xAx	Red	120	100	35	Degrees
EDEO-1xAx	Red Orange	120	100	35	Degrees
EDEA-1xAx	Amber	120	100	35	Degrees
EDET-1xAx	True Green	150	110	40	Degrees
EDEB-1xAx	Blue	150	110	40	Degrees
EDEC-1xAx	Royal Blue	150	110	40	Degrees

Part Name	Color	$\Theta_{\text{PEAK}}(\text{Typ.})$		Units
		Batwing	Side emitting	
EDEW-1xAx	White	± 40	± 80	Degrees
EDEW-1SA6	White	--	± 80	Degrees
EDEW-1SA7	White	--	± 80	Degrees
EDEX-1xAx	Warm White	± 40	± 80	Degrees
EDER-1xAx	Red	± 35	± 80	Degrees
EDEO-1xAx	Red Orange	± 35	± 80	Degrees
EDEA-1xAx	Amber	± 35	± 80	Degrees
EDET-1xAx	True Green	± 40	± 80	Degrees
EDEB-1xAx	Blue	± 40	± 80	Degrees
EDEC-1xAx	Royal Blue	± 40	± 80	Degrees

Note

1. Flux is measured with an accuracy of $\pm 10\%$.
2. CCT selection acc. to CCT groups and an accuracy of $\pm 200\text{K}$
3. Forward Voltage is measured with an accuracy of $\pm 0.1\text{V}$
4. Wavelength is measured with an accuracy of $\pm 0.5\text{nm}$
5. All white 、 warm white 、 True green and blue emitters are built with InGaN
6. All red 、 red-orange and amber emitters are built with AlGaInP

JEDEC Moisture Sensitivity:

Level	Floor Life		Soak Requirements			
	Time	Conditions	Standard Time (hours)	Conditions	Accelerated Environment Time (hours)	Conditions
4	72hours	≤30°C / 60% RH	96 +2/-0	30°C / 60% RH	20 +0.5/-0	60°C / 60% RH

LEVEL	FLOOR LIFE		SOAK REQUIREMENTS			
			STANDARD		ACCELERATED EQUIVALENT ¹	
	TIME	CONDITIONS	TIME (hours)	CONDITIONS	TIME (hours)	CONDITIONS
1	Unlimited	≤30°C/85% RH	168 +5/-0	85°C/85% RH		
2	1 year	≤30°C/80% RH	168 +5/-0	85°C/80% RH		
2a	4 weeks	≤30°C/80% RH	696 ² +5/-0	30°C/80% RH	120 +1/-0	60°C/80% RH
3	168 hours	≤30°C/80% RH	192 ² +5/-0	30°C/80% RH	40 +1/-0	60°C/80% RH
4	72 hours	≤30°C/80% RH	96 ² +2/-0	30°C/80% RH	20 +0.5/-0	60°C/80% RH
5	48 hours	≤30°C/80% RH	72 ² +2/-0	30°C/80% RH	15 +0.5/-0	60°C/80% RH
5a	24 hours	≤30°C/80% RH	48 ² +2/-0	30°C/80% RH	10 +0.5/-0	60°C/80% RH
6	Time on Label (TOL)	≤30°C/80% RH	TOL	30°C/80% RH		

Note

1. The standard soak time includes a default value of 24 hours for semiconductor manufacturer's exposure time (MET) between bake and bag and includes the maximum time allowed out of the bag at the distributor's facility.

Operating life, mechanical, and environmental tests performed on Edixeon[®] package:

Stress Test	Stress Conditions	Stress Duration	Failure Criteria
Room Temperature Operating Life	25°C, I _F = max DC (Note 1)	1000 hours	Note 2
High Temperature High Humidity	85°C / 85%RH	1000 hours	Note 2
Temperature Cycle	-40°C/100°C ,30 min dwell / <5min transfer	200 cycles	Note 2
High Temperature Storage Life	110°C	1000 hours	Note 2
Low Temperature Storage Life	-55°C	1000 hours	Note 2
Thermal Shock	-40 / 120°C, 20 min dwell / <20 sec transfer	200 cycles	No catastrophics
Mechanical Shock	1500 G, 0.5 msec pulse, 5 shocks each 6 axis		No catastrophics
Natural Drop	On concrete from 1.2 m, 3X		No catastrophics
Variable Vibration Frequency	10-2000-10 Hz, log or linear sweep rate, 20 G about 1 min, 1.5 mm, 3X/axis		No catastrophics
Solder Heat Resistance (SHR)	260°C ± 5°C, 10 sec		No catastrophics
Solderability	Steam age for 16 hr, then solder dip at 260°C for 5 sec		Solder coverage on lead

Note

1. Depending on the maximum derating curve.

2. Failure Criteria:

Electrical failures

V_F shift >=10%

I_R<50uA @V_r=5V

Light Output Degradation

% I_v shift >= 30% @1,000hrs or 200cycle

Visual failures

Broken or damaged package or lead

Solderability < 95% wetting

Dimension out of tolerance

Burn-in Condition Edixeon® Reliability

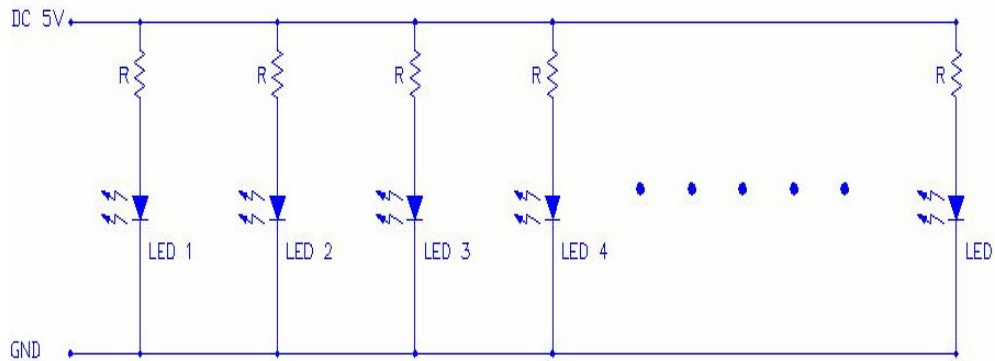

When we talk about MTBF of Edixeon®, we can provide a formula for customers.

$$\log(\text{Life}) = \frac{1,600}{T_j(^{\circ}\text{C}) + 273}$$

Life means the time light output becomes 70%

T _j (°C)	Life (hours)	T _j (°C)	Life (hours)
25	234,000	85	29,500
30	191,000	90	25,700
35	157,000	95	22,300
40	129,000	100	19,500
45	107,000	105	17,100
50	90,000	110	15,100
55	75,000	115	13,300
60	64,000	120	11,700
65	54,000	125	10,500
70	46,000	130	9,300
75	39,600	140	7,500
80	34,000	150	6,000

When we talk about MTTF of Edixeon[®], we can provide a formula for customers_
 MTTF is assumed to be 100,000,000

The failure rates at different hours and different systems(LED quantity) are as below:

if there is 1 failure of 1 emitter in a system

Tj=75°C is giving 0.01%(100ppm) at 10,000hrs

if there is 1 failure of 10 emitters in a system

Tj=75°C is giving 0.1%(1,000ppm) at 10,000hrs

if there is 1 failure of 1 emitter in a system

Tj=75°C is giving 0.05%(500ppm) at 50,000hrs

if there is 1 failure of 10 emitters in a system

Tj=75°C is giving 0.5%(5,000ppm) at 50,000hrs if there are 10 emitters

How to Know Tj in Your Application?

If it is white Edixeon[®], Rth(junction to case)=15°C/W

The thermal grease is 200um.

K(Aluminum PCB)=2.6 W/mk

$$\text{Then Rth(case to board)} = \frac{200}{2.6 \times (6.4/2)^2 \pi} = 2.4 \text{ } ^\circ\text{C/W}$$

The Rth between board and air is mainly dependent on the total surface air.

$$\text{Rth(board-air)} \doteq \frac{500}{\text{Area}(\text{cm}^2)}$$

If Area is 30cm² Rth=16.7 ΔT(junction-air)=(15+2.4+16.7)x1=34.1 °C

If Area is 60cm² Rth=8.3 ΔT(junction-air)=(15+2.4+8.3)x1=25.7 °C

If Area is 90cm² Rth=5.5 ΔT(junction-air)=(15+2.4+5.5)x1=22.9 °C

ASSIST FORM about High Power LED Reliability(White Edixeon)

	<u>Ts=45°C</u>	<u>Ts=65°C</u>	<u>Ts=85°C</u>
Voltage	3.5V	3.5V	3.5V
Current	350mA	350mA	350mA
Wattage	1.2W	1.2W	1.2W
Heat	1.0W	1.0W	1.0W
Rth	15 °C/W	15 °C/W	15 °C/W
Tj	60 °C	80 °C	100 °C
L_{70%}	64,000hrs	34,000hrs	19,500hrs

ESD Sensitivity test:

Part No.	<u>EDEX-1xAx</u>
Test Quantity	<i>Each 10 pcs</i>
Test Item	<i>ESD-HBM</i>
Test Method	<i>MIL-STD-883E Method 3015.7</i>
Class I	<i>0V ~ 1,999V</i>
Class II	<i>2,000V ~ 3,999V</i>
Class III	<i>4,000V ~ to above</i>
Failure Criteria	<i>IR>5 μA@VR=5V</i>
Test Voltage	<i>-100 ~ -500V ,Step: -100V -500 ~ -8,000V ,Step: -500V</i>
Test Date	<i>18-Mar-05</i>
Test Equipment	<i>Keytek Zapmaster</i>
Test Environmental	<i>25$^{\circ}$C\pm5$^{\circ}$C,55%\pm10%RH</i>

Sample	Voltage(V)		MIL-STD
	Forward	Reverse	
Lambertian	<i>Pass</i>	<i>Pass</i>	Class III
Side emitting	<i>Pass</i>	<i>Pass</i>	Class III
Batwing	<i>Pass</i>	<i>>500</i>	--
Focusing	<i>Pass</i>	<i>>500</i>	--

Electrical & Optical Curves-Spectrum

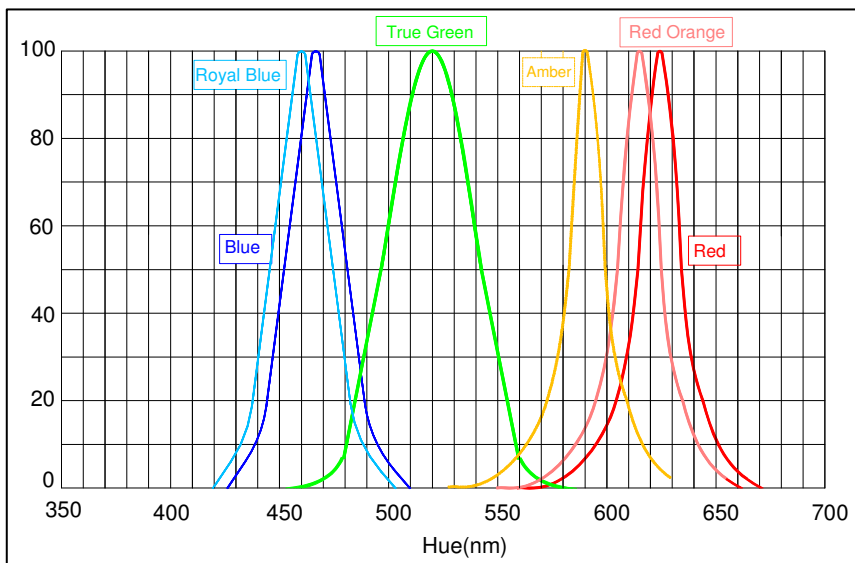
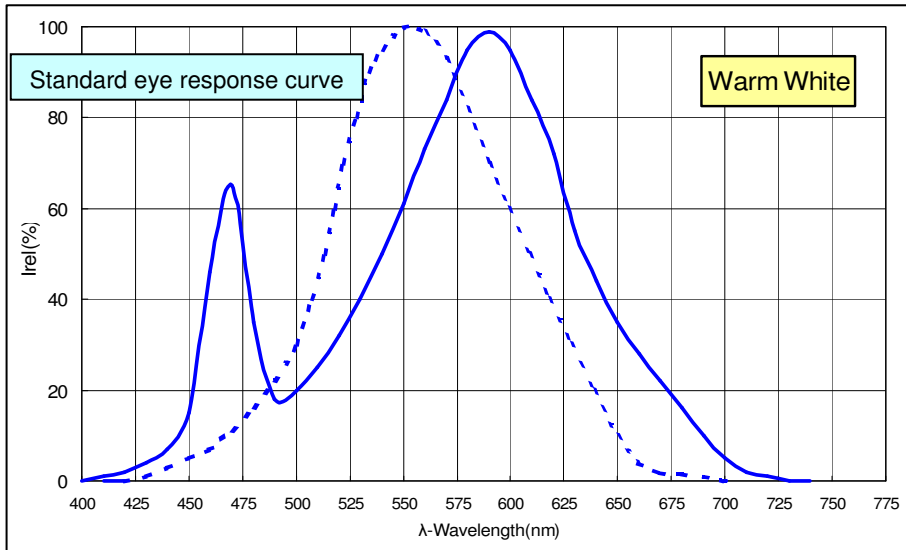
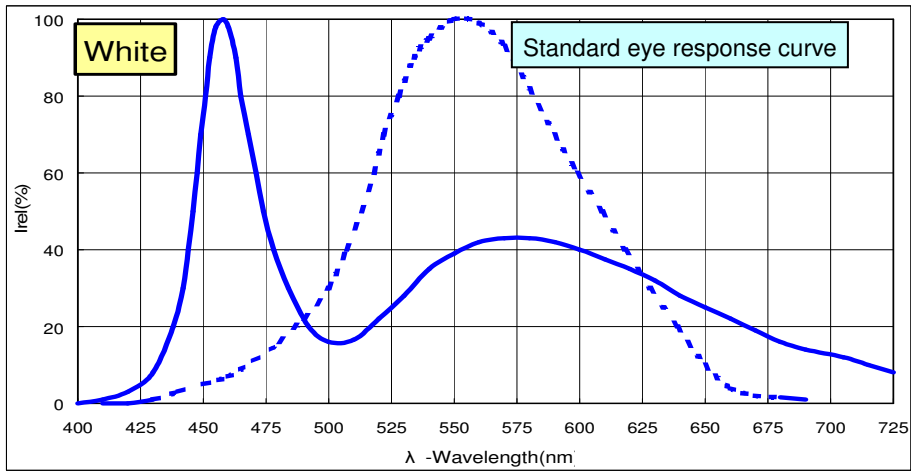

Typical Radiation Pattern for

Lambertian

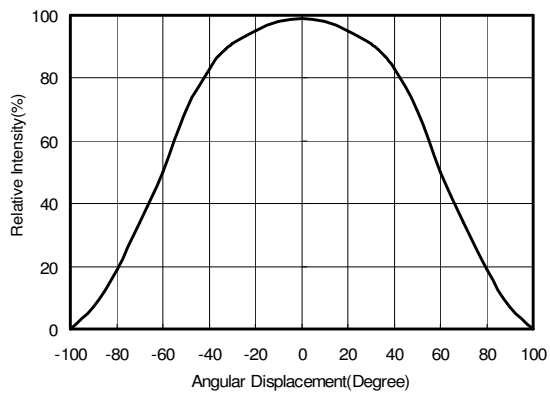

for Red 、Amber 、Red Orange 、EDEW-1LA7

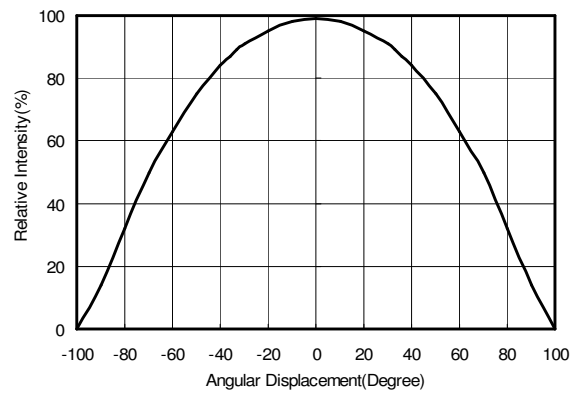

for White 、Warm white

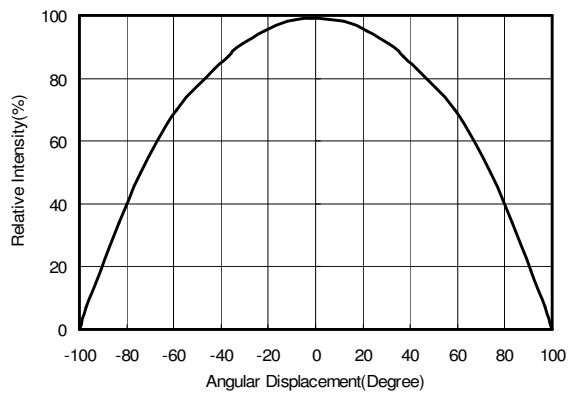

for Blue 、Royal Blue 、True Green

Side Emitting (for all colors)

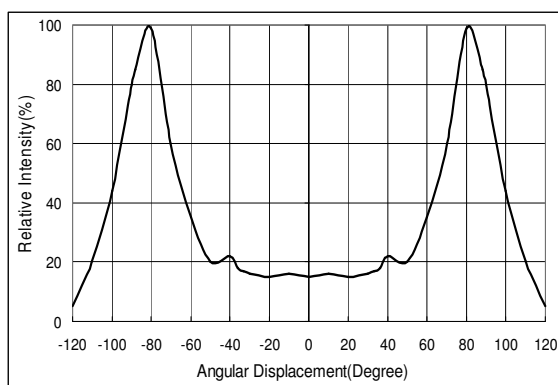

Batwing (for all colors)

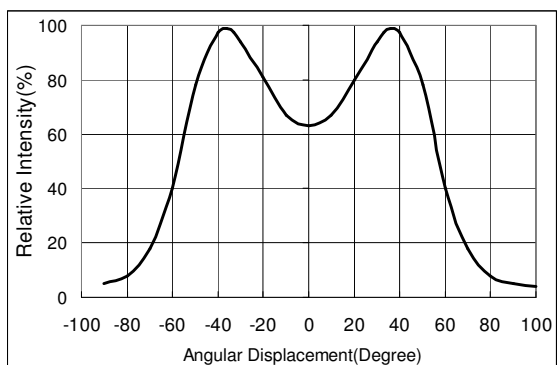

Focusing

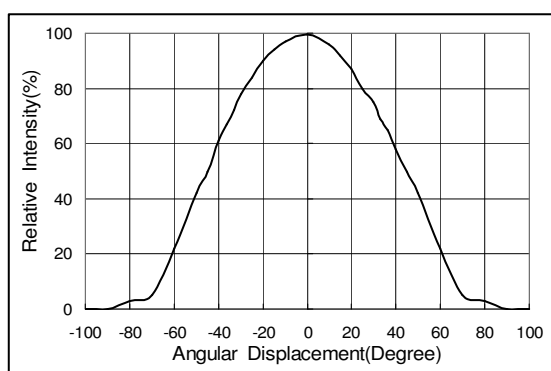

for White 、 Warm White

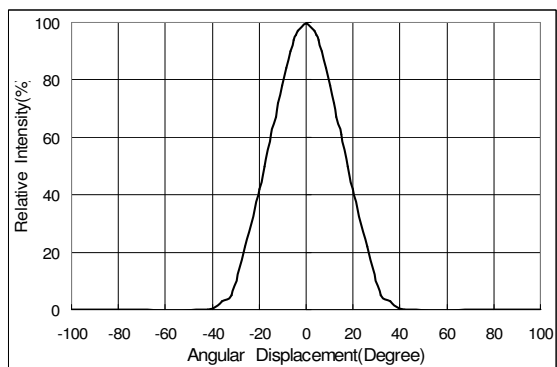

for Blue 、 Royal Blue 、 True Green
Red 、 Red Orange 、 Amber

Available Ray Data List

1W Edixeon	Provide Ray source file type	Red	Blue	True Green	White
Lambertian	From ASAP (*.DIS)	☉	△	△	△
	From Trace Pro (*.DAT)	☉	☉	☉	☉
	From Radiant Image (*.RSM)	☉	△	△	△
Batwing	From ASAP (*.DIS)	☉	☉	△	△
	From Trace Pro (*.DAT)	☉	☉	☉	☉
	From Radiant Image (*.RSM)	△	△	△	△
Side emitting	From ASAP (*.DIS)	△	△	△	△
	From Trace Pro (*.DAT)	☉	☉	☉	☉
	From Radiant Image (*.RSM)	△	△	△	△
Focusing	From ASAP (*.DIS)	△	△	△	△
	From Trace Pro (*.DAT)	△	△	△	△
	From Radiant Image (*.RSM)	△	△	△	△

Note:

1. “☉” → Ready
2. “△” → Not ready

Typical Optical and Electrical Curves

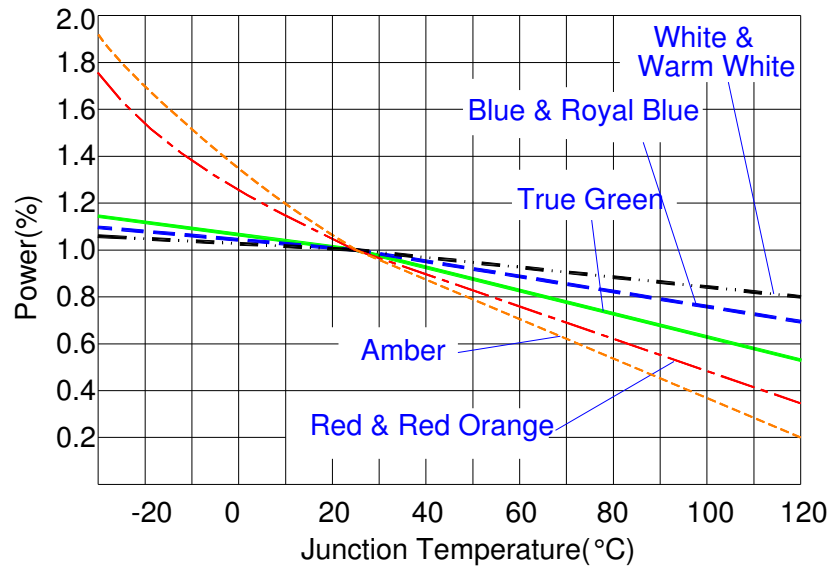

Junction Temperature & Forward Voltage

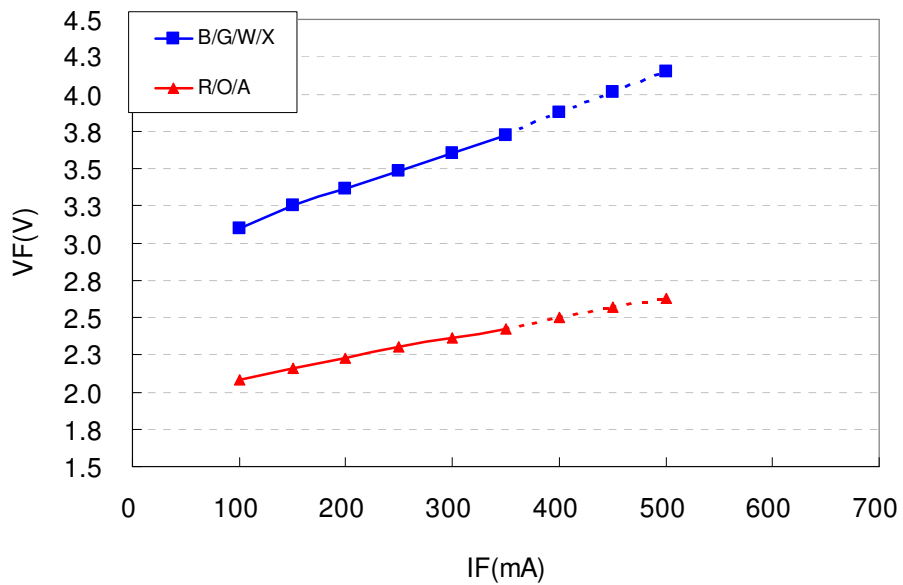

Operating Current & Forward Voltage

Typical Optical and Electrical Curves

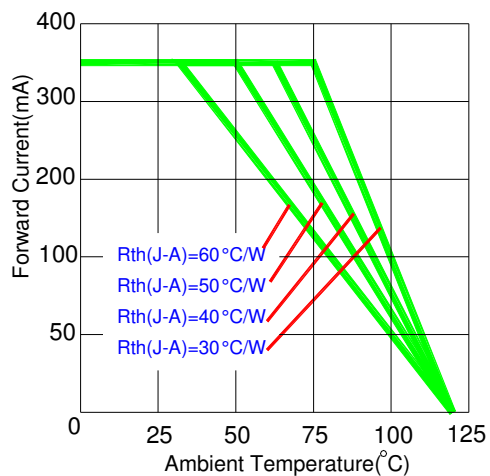

Operating Current & Ambient Temperature

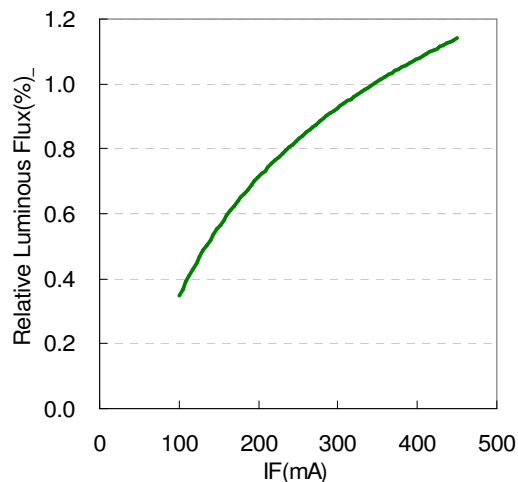

Forward Current & Luminous Flux

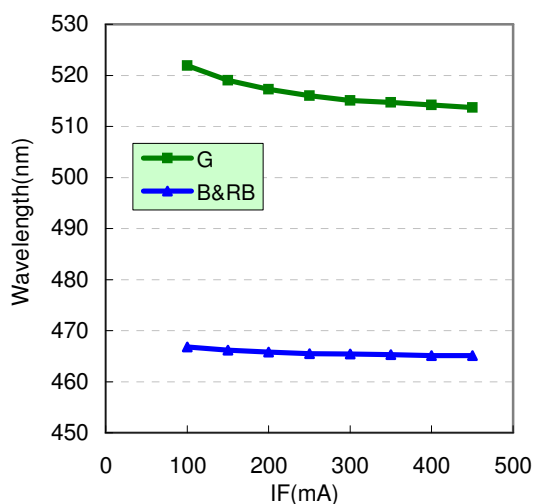

Forward Current & Wavelength

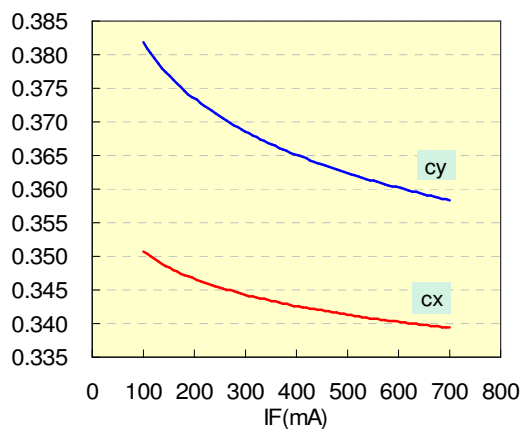
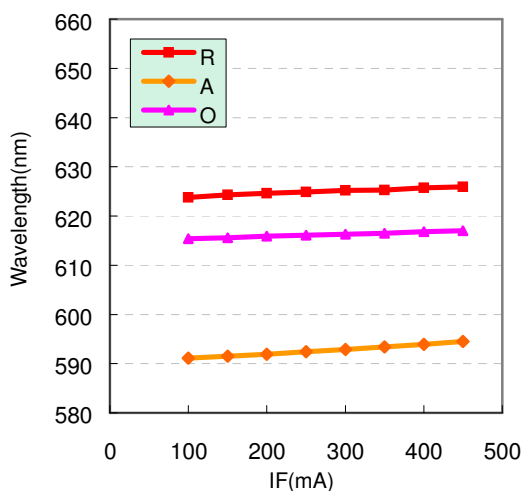

Forward Current & chromaticity coordinate

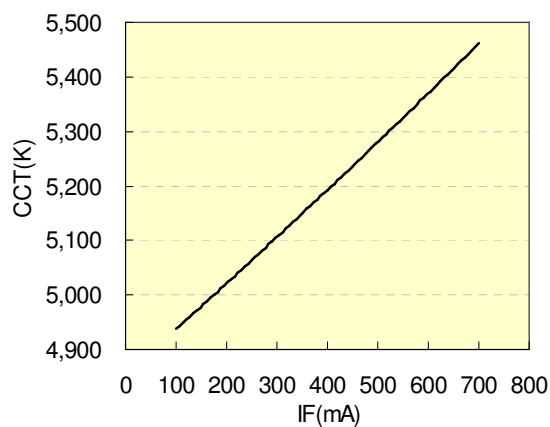

Forward Current & CCT

Recommended Solder Pad Design

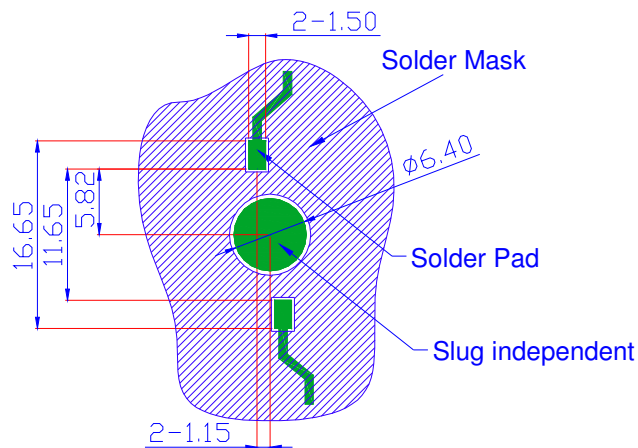

Note:

1. All dimensions are in mm.
2. The drawings are not to scale
3. Solder pad can't be connected to slug.

Recommend Solder Steps

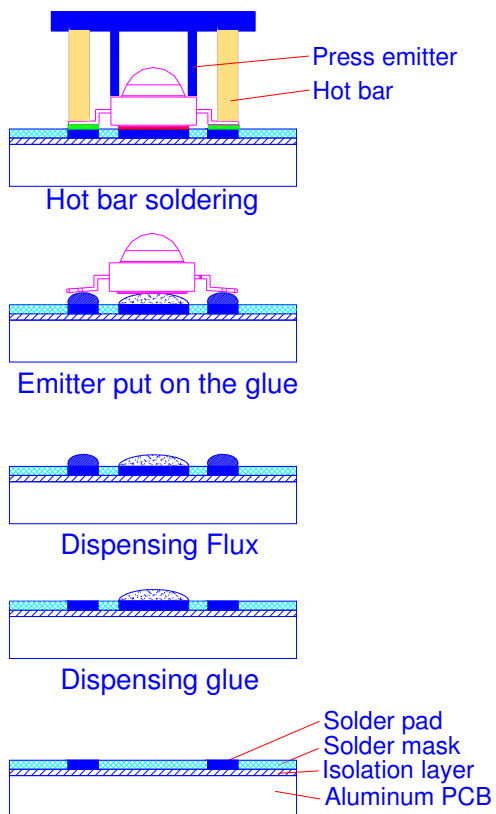

Notes:

1. Aluminum PCB material with a thermal conductivity greater than 2.0 W/mK.
2. Solder pad can't be connected to slug.
3. The Thermal glue should be as thin as possible for better heat conductivity.
4. During any assembly process touching lens is avoided. This will cause pollution or scratch on the surface of lens.
5. Thermal glue with a thermal conductivity greater than 1.0 W/mK and the thickness must be less than 100 μ m.

Adhesive for Emitter to Aluminum PCB

Suggestion:

- **Ease of use**
 - Non-solvent, One-part
- **Fast tack free**
 - 3 minutes at 25°C
- **No corrosion**
 - Alcohol type of RTV
- **Low volatility**
 - Low weight loss of silicone volatiles
- **Adhesion**
 - Excellent adhesion to most materials without use of a primer
- **Dielectric properties**
 - Cured rubber exhibits good dielectric properties
- **Excellent thermal stability and cold resistance**
 - Cured rubber provides wide service temperature range

Typical Properties

Specification	Suggested Properties
Take-free time	3~10 minutes
Specific gravity	< 3 g/cm ²
Thermal conductivity	> 2.5 W/mK
Rth in using	< 1.8 °C/W
Volume resistance	> 1x10 ¹⁴
Lap shear adhesion strength	> 200 N/ cm ²
Tensile strength	> 4 Mpa

Thrust for Edixeon Lens

Lens Type	Typical Thrust
Lambertian Lens	5 kgf
Batwing Lens	2 kgf
Side Emitting Lens	2 kgf
Focusing Lens	2 kgf

Package Specifications

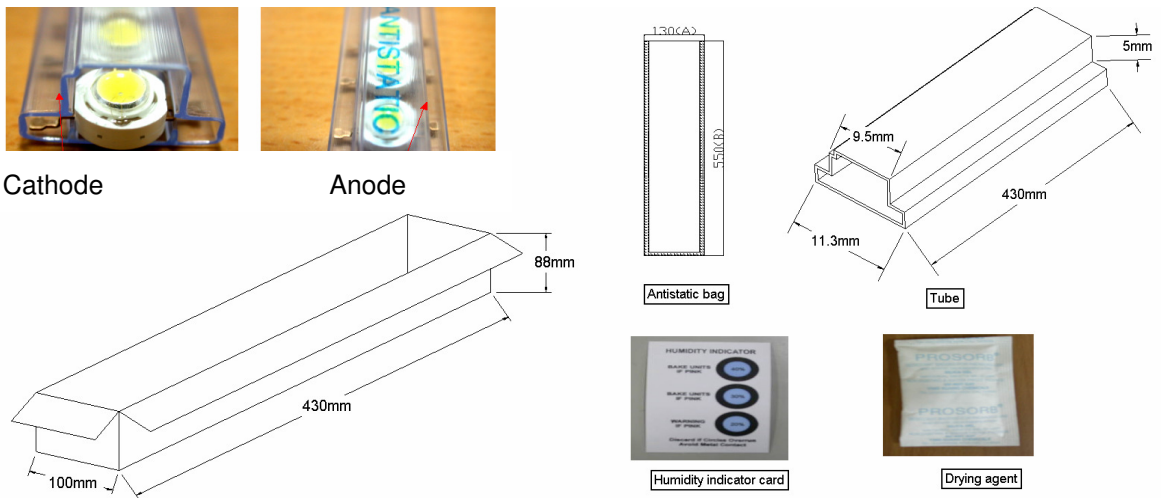

Notes

1. Inner antistatic bag standard.
2. A bag contains one humidity indicator card and drying agent.
3. 50pcs emitters per tube.
4. 20 tubes per bag, 1 K pcs per bag.
5. 2 bags per inner box, 2 K pcs per inner box.

Packing Step	Type	Dimension(mm)	Emitter Q'ty(Max.)
1	Tube	430*13	50
2	Inner Box	430*100*88	1,000
3	Outer Box	460*196*135	2,000