

EdiLine III

The linear structure of EdiLine III Series results in an easier heat dissipation requirement, making versatile fixtures design possible as well as an overall cost saving benefit. The special twin connectors design allows EdiLine to be assembled easily with screws in either serial order as a linear light source or parallel order as a planar light source.

Features

- Linear Packaging Design
- High Efficiency
- Low Power Consumption
- Long Operating Lifespan
- Easy Installation with Screws

Typical Applications

- General lighting
- Contour lights
- Ceiling lights
- Decoration lights
- Architectural lighting

Table of contents

EdiLine Nomenclature	2
Package Outline	3
Absolute Maximum Ratings.....	4
Optical and Electrical Characteristic.....	5
Color Spectrum	8

EdiLine Nomenclature

E L B W - 1 G A 0 - B 00

X1 X2 X3 X4 X5 X6 X7 X8 X9

X1 LED Item		X2 Module		X3 Emitting Color		X4 Power		X5 Serial No.		X6 Circuit Type		X7~X9 Serial No.	
Code	Type	Code	Type	Code	Type	Code	Type	Code	Type	Code	Type	Code	Type
EL	EdiLine III	B	Type III-M	W	Cool White	1	1W			A	6 Parallel with 3 Serial		
		C	Type III-L	H	Neutral White	3	3.5W			B	18 Parallel with 3 Serial		
				X	Warm White								

Package Dimension

Circuit diagram

EdiLine III-M

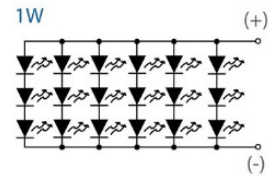
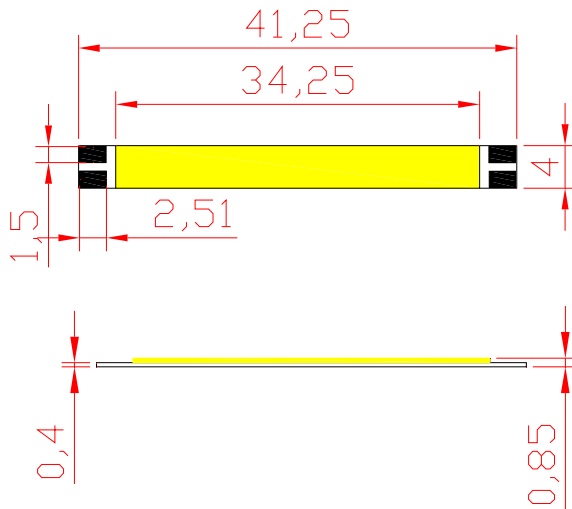

EdiLine III-L

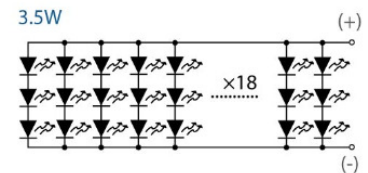
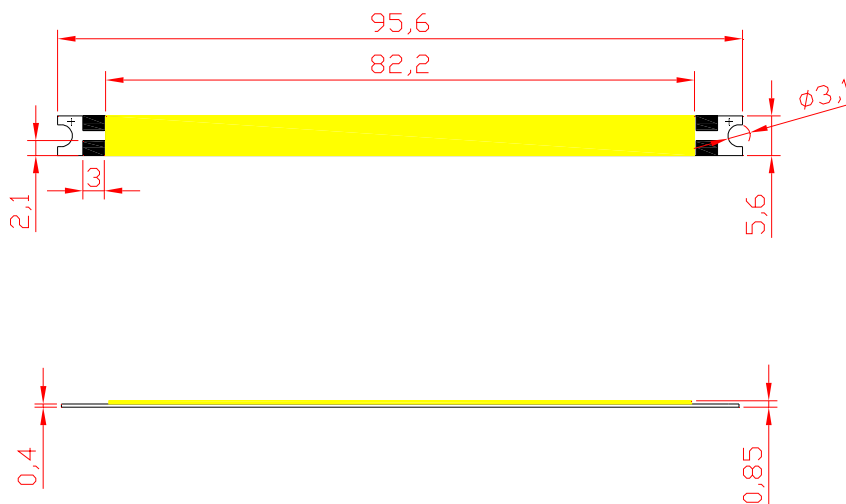

Notes:

1. All dimensions are in mm.
2. General Tolerance is 0.1mm.
3. Drawings are not to scale.
4. It is strongly recommended that the temperature of PCB be not higher than 55°C.

Absolute Maximum Ratings

Parameter	Symbol	Rating	Units
Transient Surge Voltage	V_{TS}	12	V
DC Forward Current	I_F	100	mA
		350	
LED Junction Temperature	T_j	80	°C
Operating Temperature	T_{opr}	-40 ~ +50	°C
Storage Temperature	T_{stg}	-40 ~ +120	°C
Allowable Reflow Cycles	n/a	3	cycles

Luminous Flux Characteristics ($T_j=25^\circ\text{C}$):

Part Name	Color	Test Current	Flux			Units
			Min.	Typ.	Max.	
ELBW-1GA0	Cool White	100mA	80	100	--	lm
ELBH-1GA0	Neutral White	100mA	65	80	--	lm
ELBX-1GA0	Warm White	100mA	55	70	--	lm
ELCW-3GB0	Cool White	350mA	265	330	--	lm
ELCH-3GB0	Neutral White	350mA	210	265	--	lm
ELCX-3GB0	Warm White	350mA	185	230	--	lm

Forward Voltage Characteristics ($T_j=25^\circ\text{C}$):

Part Name	Color	Test Current	V_F			Units
			Min.	Typ.	Max.	
ELBW-1GA0	Cool White	100mA	9.0	--	12.0	V
ELBH-1GA0	Neutral White	100mA	9.0	--	12.0	V
ELBX-1GA0	Warm White	100mA	9.0	--	12.0	V
ELCW-3GB0	Cool White	350mA	9.0	--	12.0	V
ELCH-3GB0	Neutral White	350mA	9.0	--	12.0	V
ELCX-3GB0	Warm White	350mA	9.0	--	12.0	V

Dominant Wavelength or Color Temperature Characteristics (T_j=25°C):

Part Name	Color	Test Current	λd/CCT			Units
			Min.	Typ.	Max.	
ELBW-1GA0	Cool White	100mA	5,000	--	10,000	K
ELBH-1GA0	Neutral White	100mA	3,800	--	5,000	K
ELBX-1GA0	Warm White	100mA	2,670	--	3,800	K
ELCW-3GB0	Cool White	350mA	5,000	--	10,000	K
ELCH-3GB0	Neutral White	350mA	3,800	--	5,000	K
ELCX-3GB0	Warm White	350mA	2,670	--	3,800	K

Temperature Coefficient of Forward Voltage & Thermal Resistance Junction to Case

Characteristics (T_j=25°C) :

Part Name	Color	Test Current	ΔV _F /ΔT		R _{θJ-B}	
			Typ.	Units	Typ.	Units
ELBW-1GA0	Cool White	100mA	-0.004	mV/°C	40	°C/W
ELBH-1GA0	Neutral White	100mA	-0.004	mV/°C	40	°C/W
ELBX-1GA0	Warm White	100mA	-0.004	mV/°C	40	°C/W
ELCW-3GB0	Cool White	350mA	-0.004	mV/°C	40	°C/W
ELCH-3GB0	Neutral White	350mA	-0.004	mV/°C	40	°C/W
ELCX-3GB0	Warm White	350mA	-0.004	mV/°C	40	°C/W

Emission Angle Characteristics (T_j=25°C):

Part Name	Color	Test Current	2θ ^{1/2} (Typ.)	2θ ^{1/2} (Typ.)	Units
			X direction	Y direction	
ELBW-1GA0	Cool White	100mA	120	140	Degrees
ELBH-1GA0	Neutral White	100mA	120	140	Degrees
ELBX-1GA0	Warm White	100mA	120	140	Degrees
ELCW-3GB0	Cool White	350mA	120	140	Degrees
ELCH-3GB0	Neutral White	350mA	120	140	Degrees
ELCX-3GB0	Warm White	350mA	120	140	Degrees

Typical Radiation Pattern

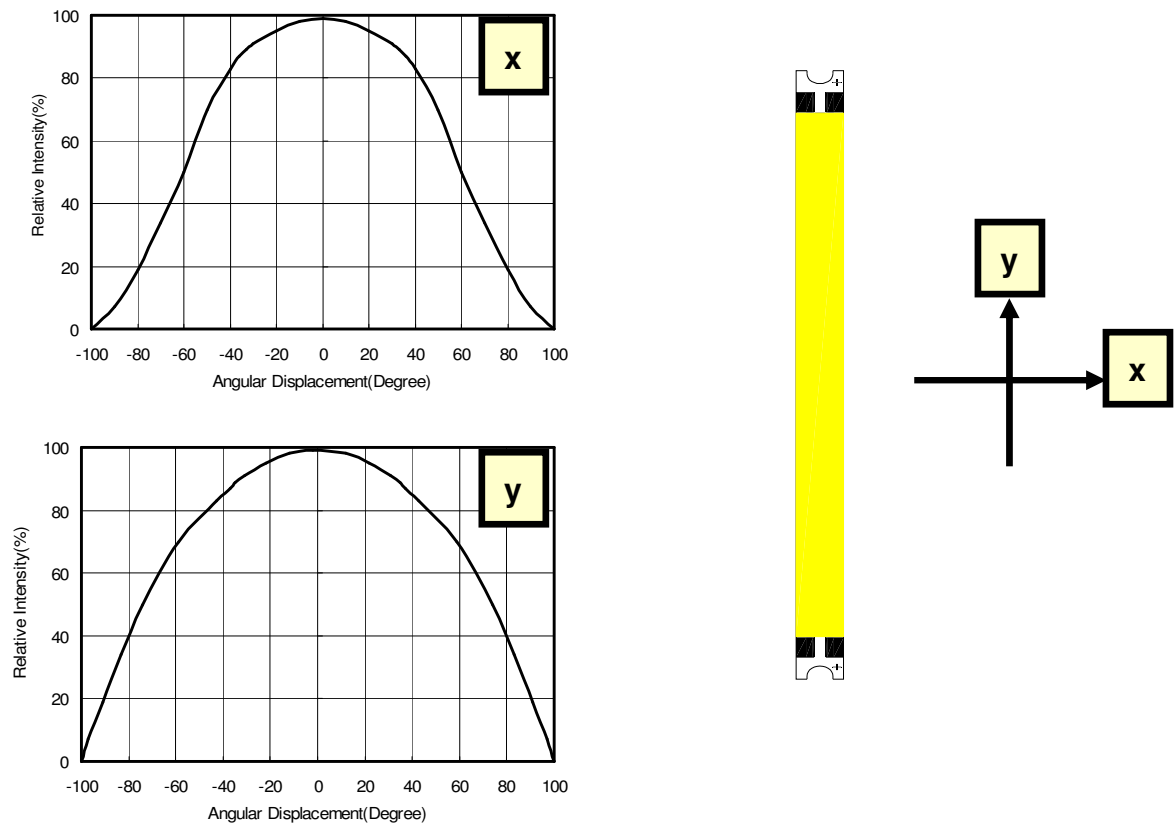

Notes

1. Flux is measured with an accuracy of $\pm 10\%$.
2. CCT selection acc. to CCT groups and an accuracy of $\pm 300K$
3. Forward Voltage is measured with an accuracy of $\pm 0.2V$
4. Wavelength is measured with an accuracy of $\pm 1nm$
5. Cool White 、 Neutral White 、 Warm White emitters are built with InGaN

Operating life, mechanical, and environmental tests performed on EdiLine package:

Stress Test	Stress Conditions	Stress Duration	Failure Criteria
Room Temperature Operating Life	25°C, I _F = max DC (Note 1)	1,000 hours	Note 2
High Temperature High Humidity	85°C / 85%RH	1,000 hours	Note 2
Thermal Shock	-40 / 120°C, 20 min dwell < 10 sec transfer	600 cycles	No catastrophic
Low Temperature Storage Life	-40°C	1,000 hours	Note 2

Notes:

Failure Criteria:

Electrical failures

V_F shift ≥ 10%

Light Output Degradation

% Iv shift ≥ 30% @1,000hrs

Visual failures

Broken or damaged package

Dimension out of tolerance

Optical Curves-Spectrum

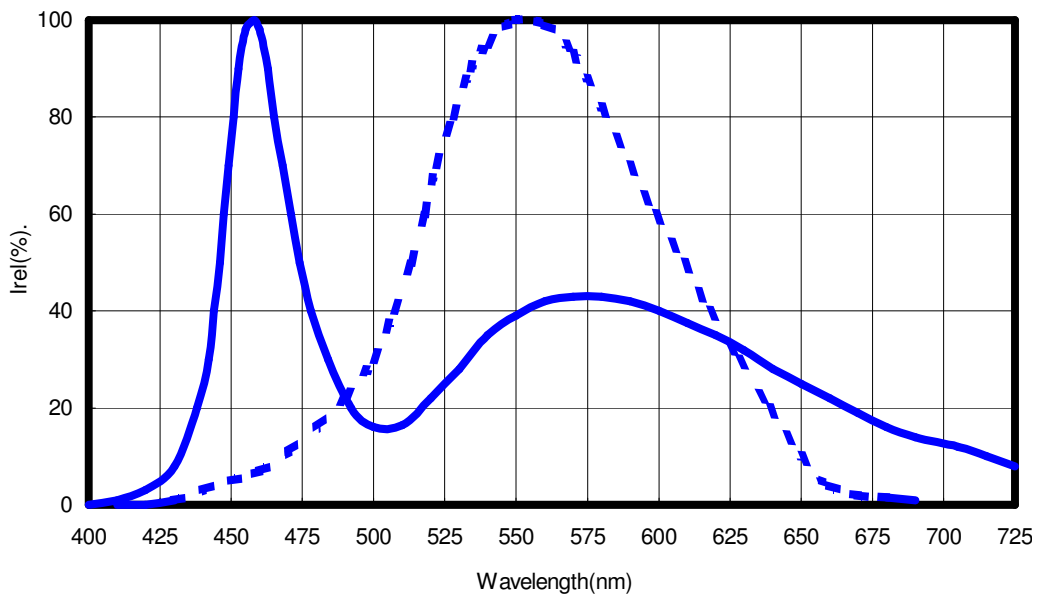

Figure 1. White color spectrum of typical CCT 、 standard eyes response to dotted curve line and CRI \approx 70 at $T_J=25^{\circ}\text{C}$.

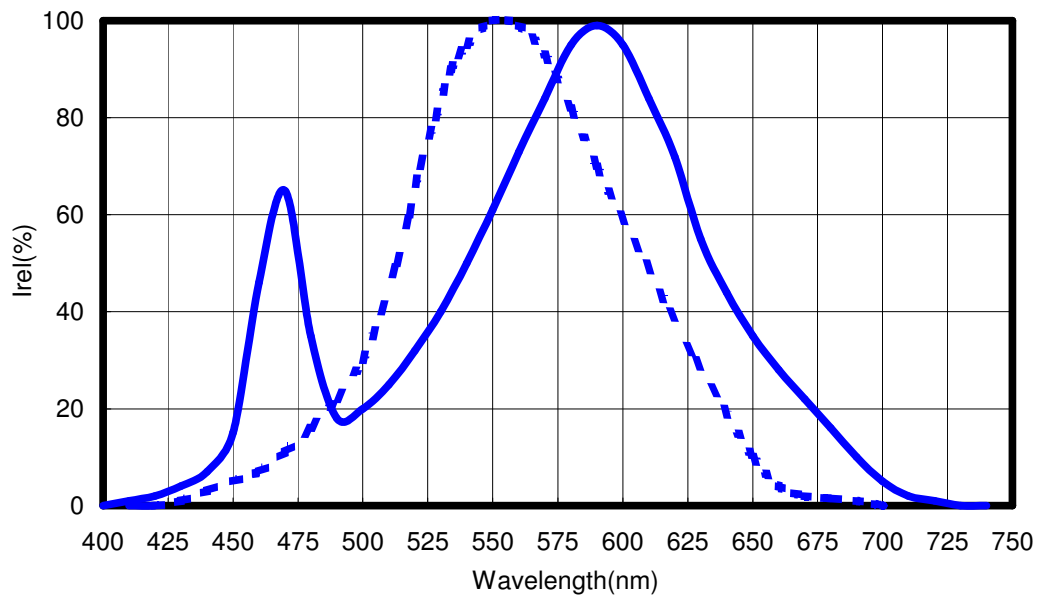

Figure 2. Warm white color spectrum of typical CCT 、 standard eyes response to dotted curve line and CRI \approx 80 at $T_J=25^{\circ}\text{C}$.