



A Solid-State Lighting Premium Expert

Table of Contents

• LBMx-F16 Series Package Dimensions and Circuit Diagram.....	3
• LBMx-F24 Series Package Dimensions and Circuit Diagram.....	4
• LBMx-F32 Series Package Dimensions and Circuit Diagram.....	5
• LBMx-F48 Series Package Dimensions and Circuit Diagram.....	6
• LBMx-F64 Series Package Dimensions and Circuit Diagram.....	7
• LBMRTB-N14/N0247 Package Dimensions and Circuit Diagram.....	8
• LBMRTB-N21/N0248 Package Dimensions and Circuit Diagram.....	9
• LBMRTB-N28/N0249 Package Dimensions and Circuit Diagram.....	10
• LBMRTB-N42/N0250 Package Dimensions and Circuit Diagram.....	11
• LBMRTB-N56/N0251 Package Dimensions and Circuit Diagram.....	12
• Absolute Maximum Ratings.....	13
• Electro-Optical Characteristics ($T_a=25^{\circ}\text{C}$).....	13
• Assembly Instructions.....	17
• Environmental Compliance.....	17
• Application Notes.....	18

LBMx-F16 Series Package Dimensions and Circuit Diagram

• Package Dimensions

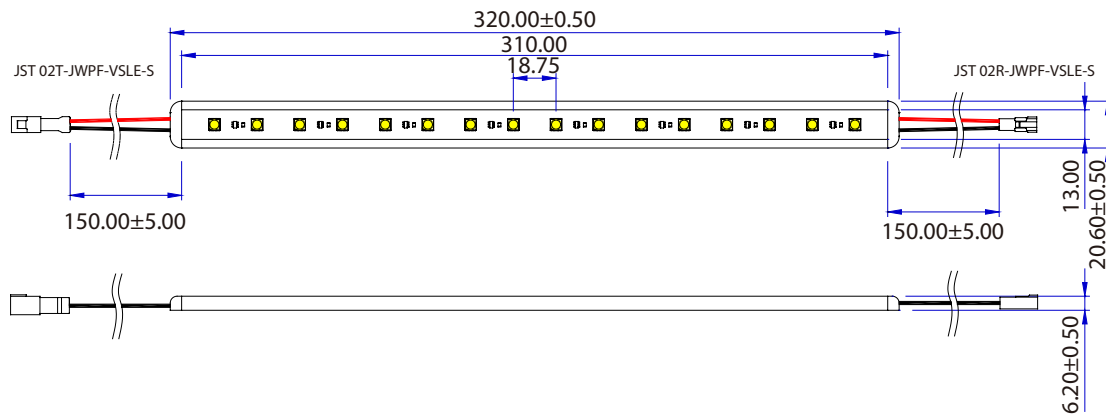

Figure 1 : LBMx-F16 series dimensions.

Note : All dimensions are in millimeters.

• Circuit Diagram

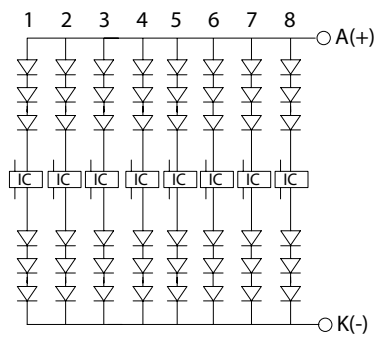

Figure 2 : LBMx-F16 series circuit diagram.

LBMx-F24 Series Package Dimensions and Circuit Diagram

• Package Dimensions

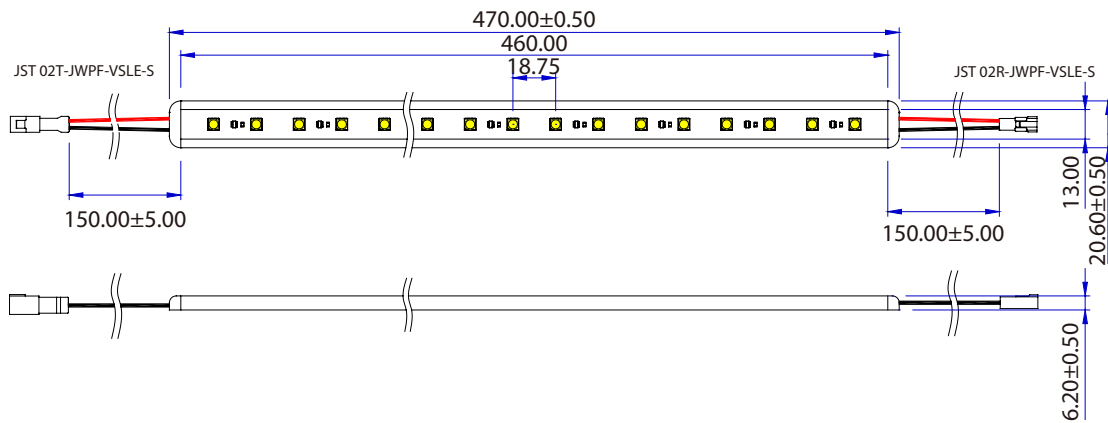

Figure 3 : LBM-F24 series dimensions.

Note : All dimensions are in millimeters.

• Circuit Diagram

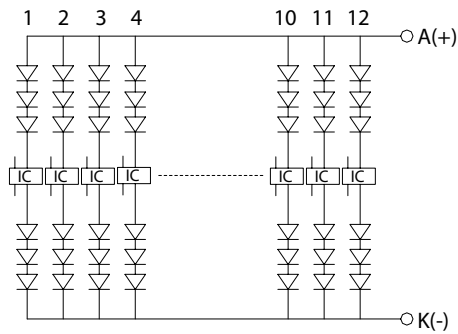

Figure 4 : LBMx-F24 series circuit diagram.

LBMx-F32 Series Package Dimensions and Circuit Diagram

• Package Dimensions

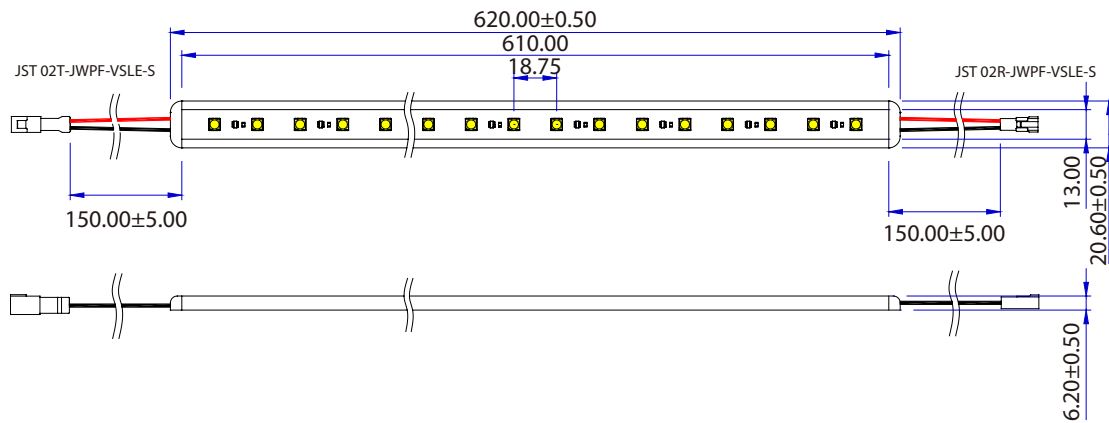

Figure 5 : LBMx-F32 series dimensions.

Note : All dimensions are in millimeters.

• Circuit Diagram

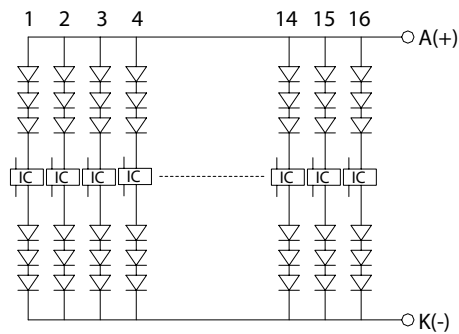

Figure 6 : LBMx-F32 series circuit diagram.

LBMx-F48 Series Package Dimensions and Circuit Diagram

• Package Dimensions

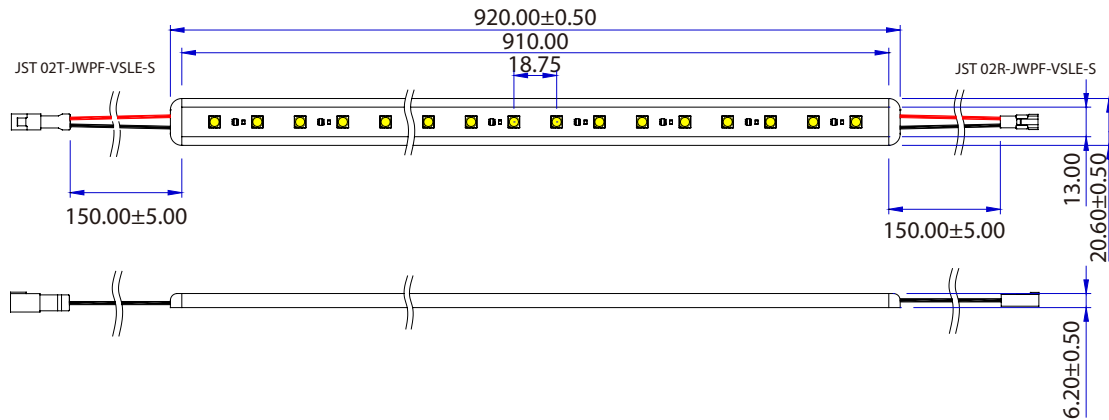

Figure 7 : LBMx-F48 series dimensions.

Note : All dimensions are in millimeters.

• Circuit Diagram

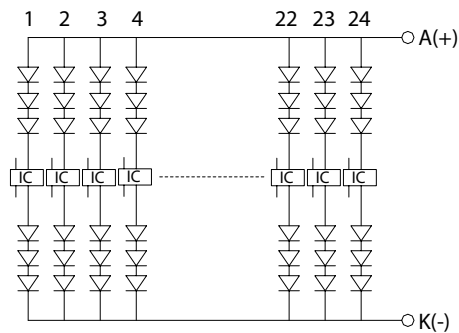

Figure 8 : LBMx-F48 series circuit diagram.

LBMx-F64 Series Package Dimensions and Circuit Diagram

• Package Dimensions

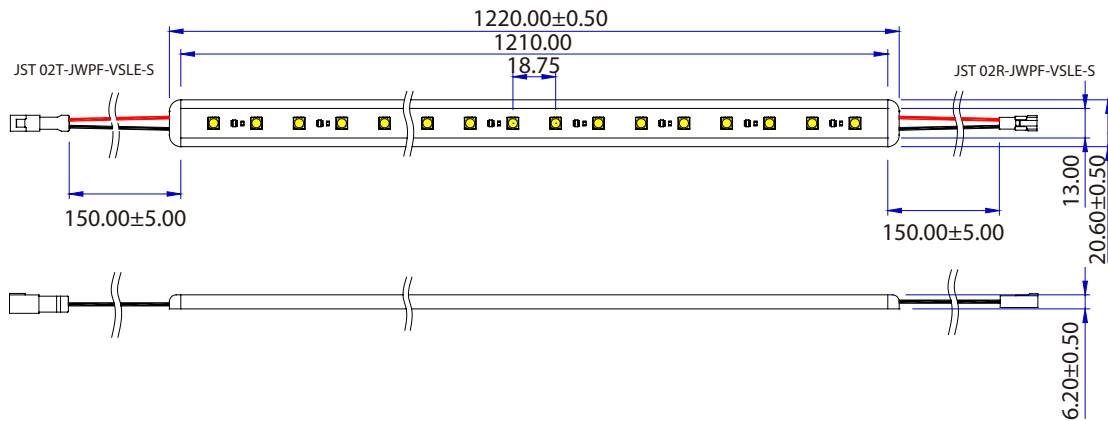

Figure 9 : LBMx-F64 series dimensions.

Notes : All dimensions are in millimeters.

• Circuit Diagram

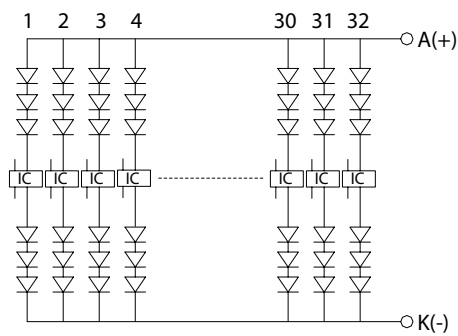

Figure 10 : LBMx-F64 series circuit diagram.

LBMRTB-N14/N0647 Package Dimensions and Circuit Diagram

• Package Dimensions

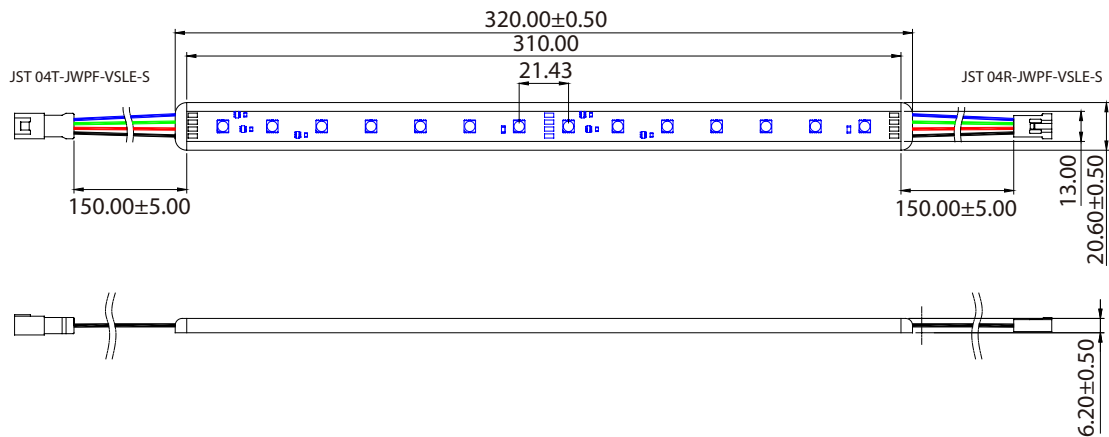

Figure 11 : LBMRTB-N14/N0647 dimensions.

Notes : All dimensions are in millimeters.

• Circuit Diagram

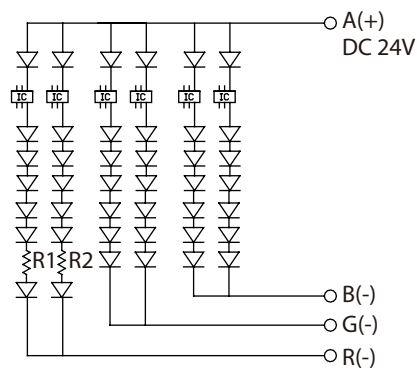

Figure 12 : LBMRTB-N14/N0647 circuit diagram.

LBMRTB-N21/N0648 Package Dimensions and Circuit Diagram

• Package Dimensions

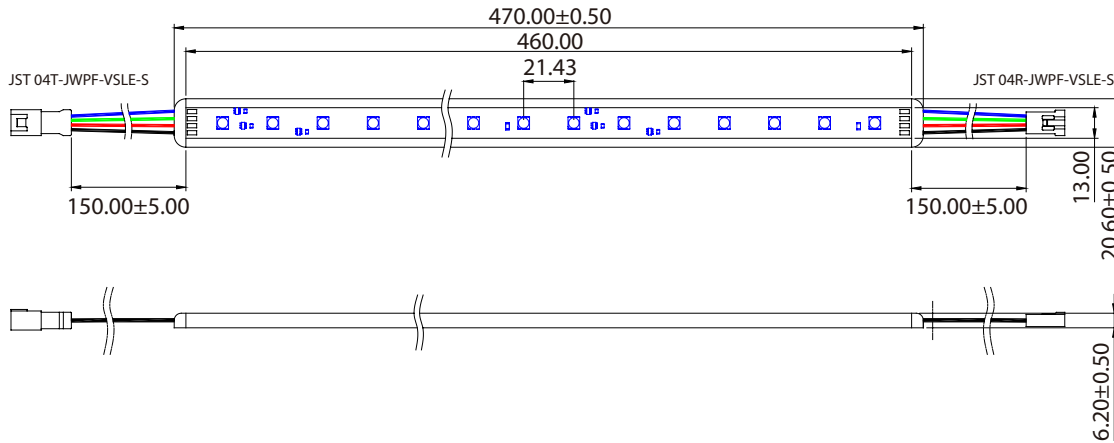

Figure 13 : LBMRTB-N21/N0648 dimensions.

Notes : All dimensions are in millimeters.

• Circuit Diagram

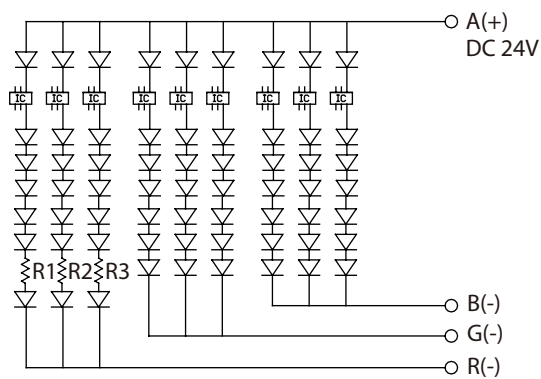

Figure 14 : LBMRTB-N21/N0648 circuit diagram.

LBMRTB-N28/N0649 Package Dimensions and Circuit Diagram

• Package Dimensions

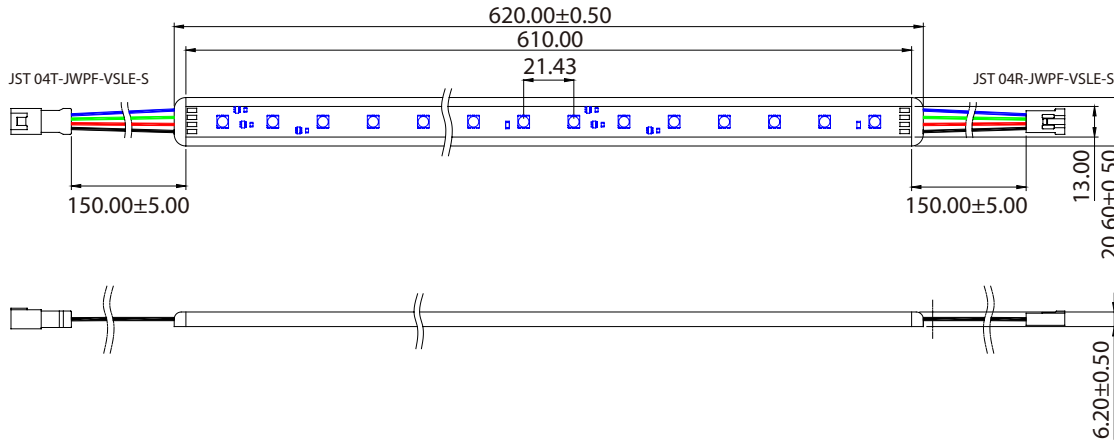

Figure 15 : LBMRTB-N28/N0649 dimensions.

Notes : All dimensions are in millimeters.

• Circuit Diagram

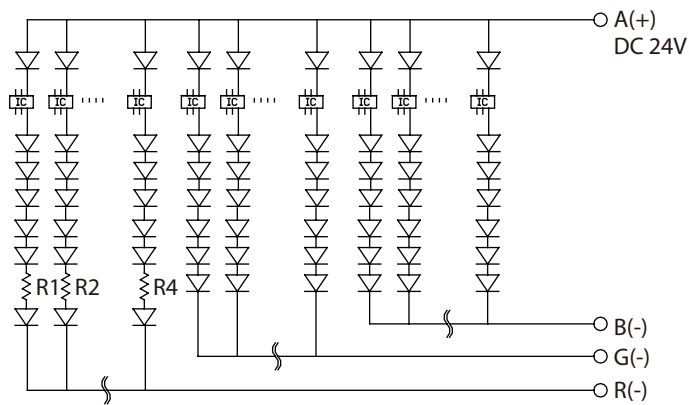

Figure 16 : LBMRTB-N28/N0649 circuit diagram.

LBMRTB-N42/N0650 Package Dimensions and Circuit Diagram

• Package Dimensions

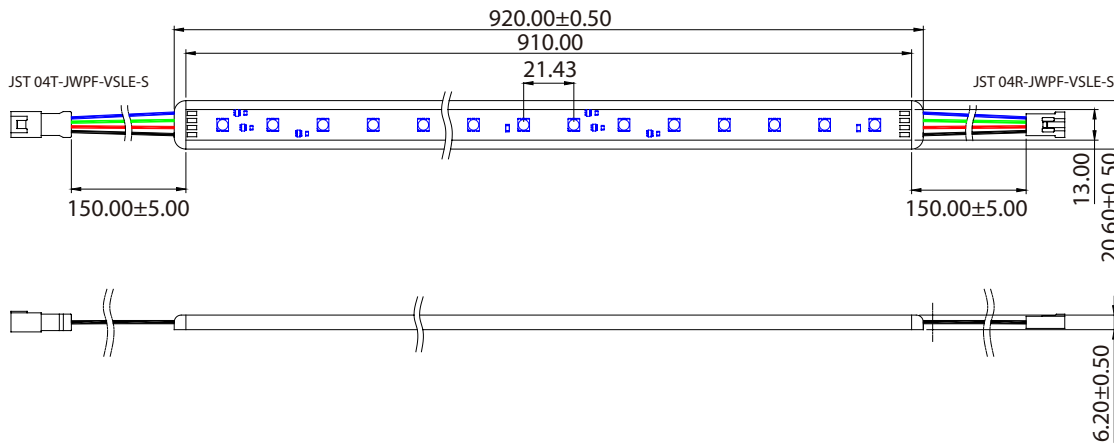

Figure 17 : LBMRTB-N42/N0650 dimensions.

Notes : All dimensions are in millimeters.

• Circuit Diagram

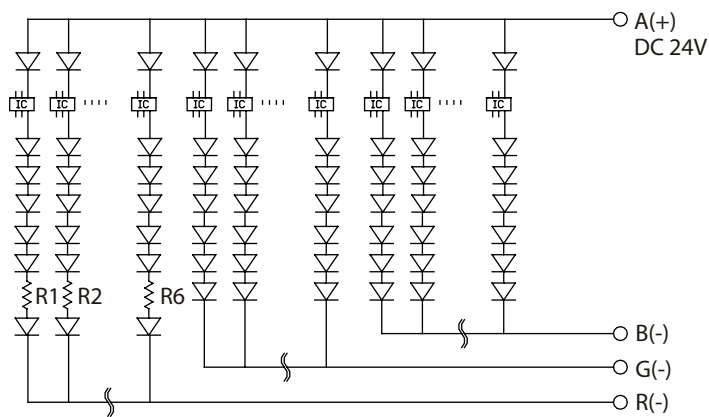

Figure 18 : LBMRTB-N42/N0650 circuit diagram.

LBMRTB-N56/N0651 Package Dimensions and Circuit Diagram

• Package Dimensions

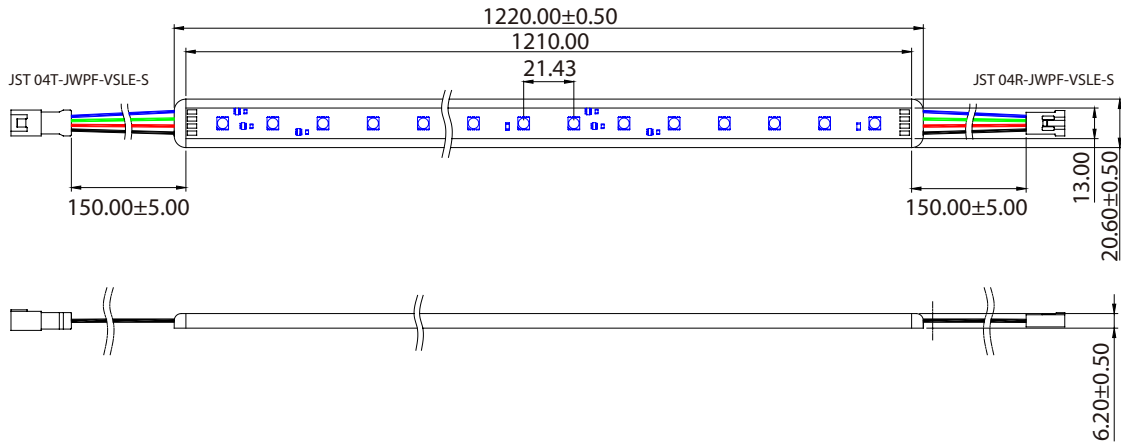

Figure 19 : LBMRTB-N56/N0651 dimensions.

Notes : All dimensions are in millimeters.

• Circuit Diagram

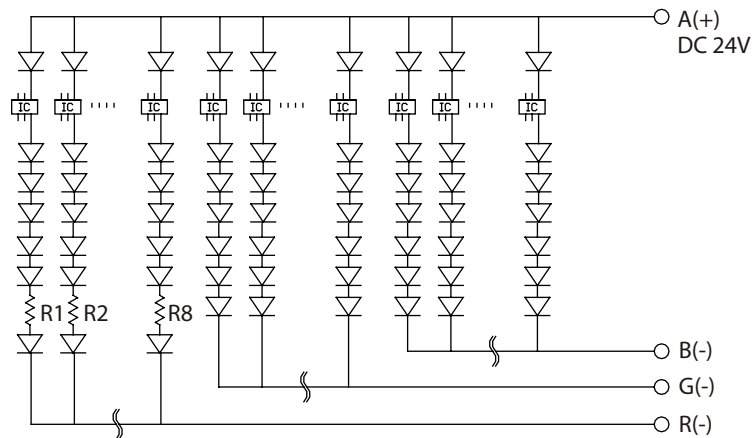

Figure 20 : LBMRTB-N56/N0651 circuit diagram.

Absolute Maximum Ratings

Parameter	Symbol	Rating	Units
LED Junction Temperature	T_j	125	°C
Operating Temperature	T_{opr}	-30 ~ +85	°C
Storage Temperature	T_{stg}	-40 ~ +85	°C

Table 1 : Absolute maximum ratings for PLCC lightbar with heatsink series.

Notes:

1. Proper current derating must be observed to maintain junction temperature below the maximum at all time.
2. LEDs are not designed to be driven in reverse bias.

Electro-Optical Characteristics ($T_a=25^{\circ}\text{C}$)

• LBMx-F16 Series

Part No.	Color	Number of LEDs	Input Voltage (V DC)	Power (W)	Current (mA)	Radiance Angle	$\lambda_d(\text{nm})/\text{CCT}(\text{K})$	Lumen Flux(lm)
LBMR-F16/N0247	Red	16	15	2.40	160	120°	620~630nm	58
LBMV-F16/N0247	Yellow	16	15	2.40	160	120°	585~595nm	62
LBMA-F16/N0247	Amber	16	15	2.40	160	120°	610~620nm	58
LBMG-F16/N0247	True Green	16	24	3.84	160	120°	520~535nm	133
LBMB-F16/N0247	Blue	16	24	3.84	160	120°	465~475nm	37
LBMW-F16/A0247	Cool White	16	24	3.84	160	120°	6000K	192
LBMH-F16/D0247	Neutral White	16	24	3.84	160	120°	4100K	163
LBMX-F16/D0247	Warm White	16	24	3.84	160	120°	3050K	163

Table 2 : LBMx-F16 series electric-optical characteristics.

Note : Flux is measured with an accuracy of $\pm 10\%$.

• LBMx-F24 Series

Part No.	Color	Number of LEDs	Input Voltage (V DC)	Power (W)	Current (mA)	Radiance Angle	λ_d (nm)/ CCT(K)	Lumen Flux(lm)
LBMR-F24/N0248	Red	24	15	3.60	240	120°	620~630nm	87
LBMF-F24/N0248	Yellow	24	15	3.60	240	120°	585~595nm	94
LBMA-F24/N0248	Amber	24	15	3.60	240	120°	610~620nm	87
LBMG-F24/N0248	True Green	24	24	5.76	240	120°	520~535nm	200
LBMB-F24/N0248	Blue	24	24	5.76	240	120°	465~475nm	56
LBMW-F24/A0248	Cool White	24	24	5.76	240	120°	6000K	288
LBMH-F24/D0248	Neutral White	24	24	5.76	240	120°	4100K	245
LBMX-F24/D0248	Warm White	24	24	5.76	240	120°	3050K	245

Table 3 : LBMx-F24 series electric-optical characteristics.

Note : Flux is measured with an accuracy of $\pm 10\%$.

• LBMx-F32 Series

Part No.	Color	Number of LEDs	Input Voltage (V DC)	Power (W)	Current (mA)	Radiance Angle	λ_d (nm)/ CCT(K)	Lumen Flux(lm)
LBMR-F32/N0249	Red	32	15	4.80	320	120°	620~630nm	116
LBMF-F32/N0249	Yellow	32	15	4.80	320	120°	585~595nm	125
LBMA-F32/N0249	Amber	32	15	4.80	320	120°	610~620nm	116
LBMG-F32/N0249	True Green	32	24	7.68	320	120°	520~535nm	266
LBMB-F32/N0249	Blue	32	24	7.68	320	120°	465~475nm	75
LBMW-F32/A0249	Cool White	32	24	7.68	320	120°	6000K	384
LBMH-F32/D0249	Neutral White	32	24	7.68	320	120°	4100K	326
LBMX-F32/D0249	Warm White	32	24	7.68	320	120°	3050K	326

Table 4 : LBMx-F32 series electric-optical characteristics.

Note : Flux is measured with an accuracy of $\pm 10\%$.

• LBMx-F48 Series

Part No.	Color	Number of LEDs	Input Voltage (V DC)	Power (W)	Current (mA)	Radiance Angle	λ_d (nm)/ CCT(K)	Lumen Flux(lm)
LBMR-F48/N0250	Red	48	15	7.20	480	120°	620~630nm	175
LBMV-F48/N0250	Yellow	48	15	7.20	480	120°	585~595nm	187
LBMA-F48/N0250	Amber	48	15	7.20	480	120°	610~620nm	175
LBMG-F48/N0250	True Green	48	24	11.52	480	120°	520~535nm	399
LBMB-F48/N0250	Blue	48	24	11.52	480	120°	465~475nm	112
LBMW-F48/A0250	Cool White	48	24	11.52	480	120°	6000K	576
LBMH-F48/D0250	Neutral White	48	24	11.52	480	120°	4100K	490
LBMX-F48/D0250	Warm White	48	24	11.52	480	120°	3050K	490

Table 5 : LBMx-F48 series electric-optical characteristics.

Note : Flux is measured with an accuracy of $\pm 10\%$.

• LBMx-F64 Series

Part No.	Color	Number of LEDs	Input Voltage (V DC)	Power (W)	Current (mA)	Radiance Angle	λ_d (nm)/ CCT(K)	Lumen Flux(lm)
LBMR-F64/N0251	Red	64	15	9.60	640	120°	620~630nm	233
LBMV-F64/N0251	Yellow	64	15	9.60	640	120°	585~595nm	250
LBMA-F64/N0251	Amber	64	15	9.60	640	120°	610~620nm	233
LBMG-F64/N0251	True Green	64	24	15.36	640	120°	520~535nm	532
LBMB-F64/N0251	Blue	64	24	15.36	640	120°	465~475nm	150
LBMW-F64/A0251	Cool White	64	24	15.36	640	120°	6000K	768
LBMH-F64/D0251	Neutral White	64	24	15.36	640	120°	4100K	630
LBMX-F64/D0251	Warm White	64	24	15.36	640	120°	3050K	630

Table 6 : LBMx-F64 series electric-optical characteristics.

Note : Flux is measured with an accuracy of $\pm 10\%$.

• LBMRTB-Nxx/N06xx Series

Part No.	Color	Number of LEDs	Input Voltage (V DC)	Power (W)	Current (mA)	Radiance Angle	λ_d (nm)/ CCT(K)	Lumen Flux(lm)
LBMRTB-N14/ N0247	Red	14	24	0.96	40	120°	620~630nm	16.8
	True Green						520~535nm	38.08
	Blue						465~475nm	11.2
LBMRTB-N21/ N0248	Red	21	24	1.44	60	120°	620~630nm	25.2
	True Green						520~535nm	57.12
	Blue						465~475nm	16.8
LBMRTB-N28/ N0249	Red	28	24	1.92	80	120°	620~630nm	36.6
	True Green						520~535nm	76.16
	Blue						465~475nm	22.4
LBMRTB-N42/ N0250	Red	42	24	2.88	120	120°	620~630nm	50.4
	True Green						520~535nm	114.24
	Blue						465~475nm	33.6
LBMRTB-N56/ N0251	Red	56	24	3.84	160	120°	620~630nm	67.2
	True Green						520~535nm	152.32
	Blue						465~475nm	44.8

Table 7 : LBMRTB-Nxx/N06xx series electrico-optical characteristics.

Note : Flux is measured with an accuracy of $\pm 10\%$.

Assembly Instructions

1. Use M3 screw to secure the clamp on a level surface.
2. Push lock the light bar.

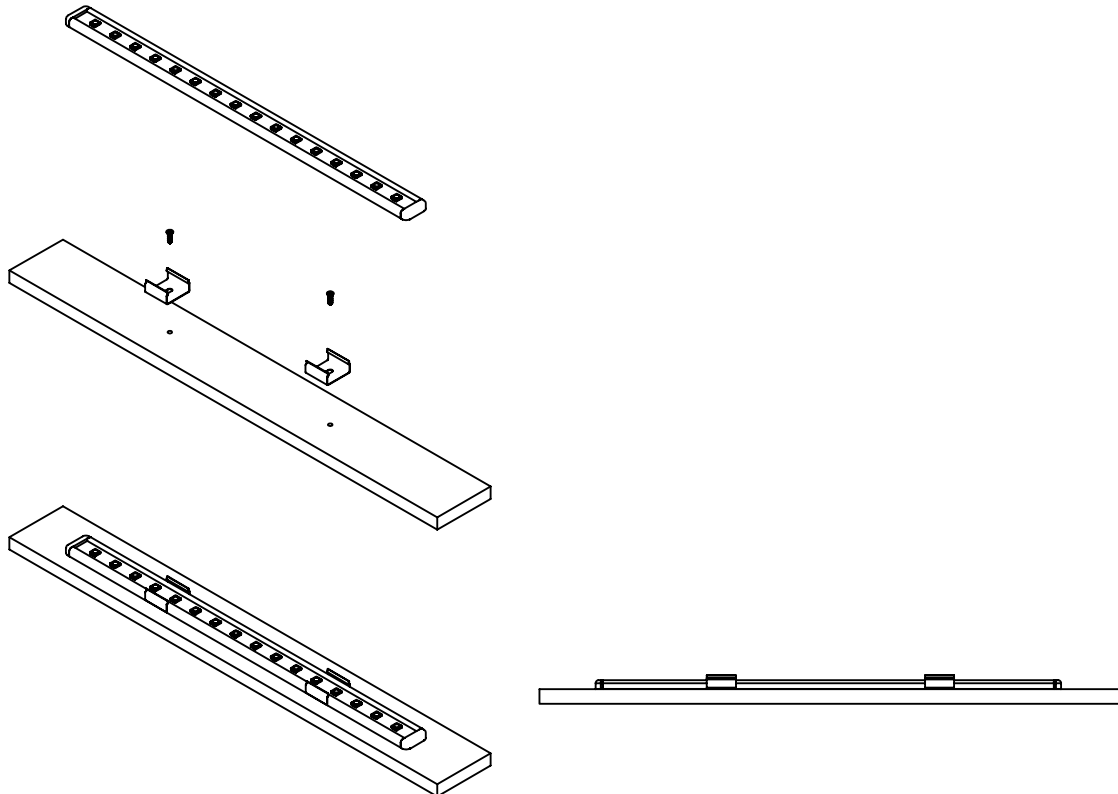

Figure 21 : PLCC lightbar with heatsink series (IP67) Assembly Instructions.

Note : Every lightbar comes with a set of accessories including two clamps and two M3 screws.

Environmental Compliance

PLCC lightbar with heatsink series are compliant to the Restriction of Hazardous Substances Directive or RoHS. The restricted materials including lead, mercury cadmium hexavalent chromium, polybrominated biphenyls (PBB) and polybrominated diphenyl ether (PBDE) are not used in PLCC lightbar with heatsink series to provide an environmentally friendly product to the customers.



A Solid-State Lighting Premium Expert

Application Notes

PLCC Lightbar series are available in red, yellow, green, blue, white, neutral white and warm white for application such as under-cabinet lighting, cove lighting and wall washing. Moreover, additional fine-tuned high color rendering index (CRI) version of white, neutral white and warm white all make PLCC Lightbar the ideal lighting choice for vividly displaying fruit and vegetables and/or refrigeration products, presenting the true color of the products and reflecting the freshness of goods.

